

Contemporary Slab & Batten Doors

"Finish Sanding is in our price... not tacked on later!"

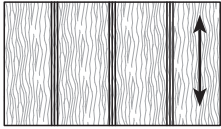

**Style 1050*
Drawer Front**

Frame Group: NA
Price Class: 503
Min. Size: 5x4³/₈

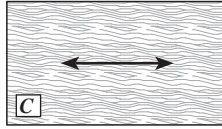

**1270*
Drawer Front**

Frame Group: NA
Price Class: 500
Min. Size: 3x3

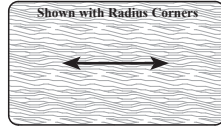

**1270*
Drawer Front**

Frame Group: NA
Price Class: 500
Min. Size: 3x3

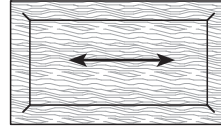

**Style 1271
Door or Drawer Front**

Frame Group: NA
Price Class: 502
Min. Size: *See Web Site*

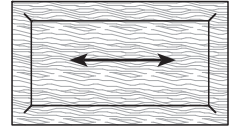

**Style 1272
Door or Drawer Front**

Frame Group: NA
Price Class: 502
Min. Size: *See Web Site*

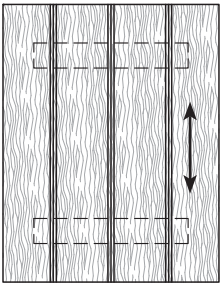

Style 1050

Frame Group: NA
Price Class: 503
Min. Size: 6x4³/₈

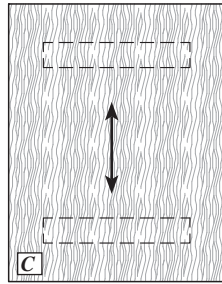

Style 1270

Frame Group: NA
Price Class: 501
Min. Size: 6x4³/₈

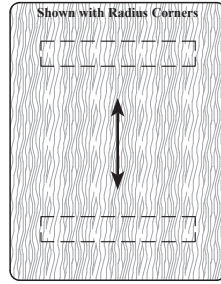

Style 1270

Frame Group: NA
Price Class: 501
Min. Size: 6x4³/₈

Minimum Size Calculation for Door Style #'s 1271 and 1272 when using a Drawer Front Profile:

The minimum size for drawer fronts is calculated using the *Raised Panel Profile Reveal* and the *Outside Edge Profile Dimension*, while maintaining a 1" minimum of flat to the face. These dimensions can be found on our *Web Site* under Technical Information.

Example: D15 Outside Edge Profile @ 3/8" x 2 = 3/4" + PR301-13 Raised Panel Profile @ 1/2" x 2 = 1" + 1" Flat = 2 3/4"

- The [C] indicates door styles that are available for Curved Products, for additional ordering guidelines, see our Specification Catalog.

Style 1050 Cross Section

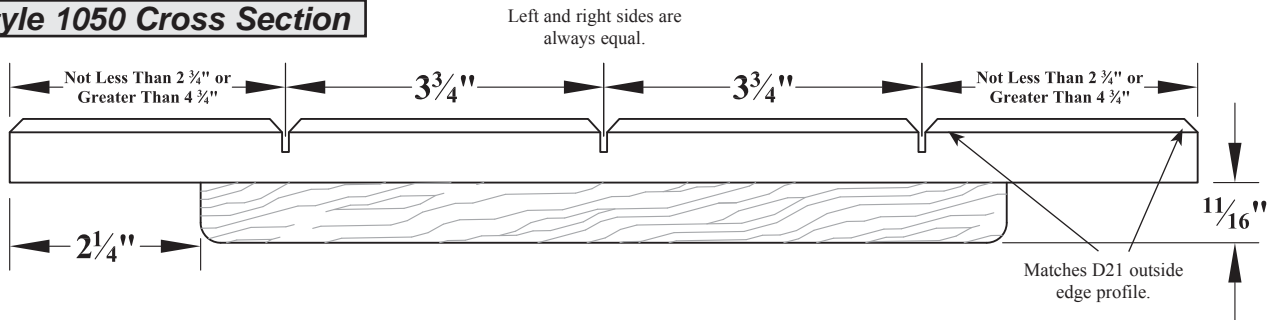

Slab & Batten Door Notes

- **Styles 1050, 1270, 1271 & 1272 are not** recommended for use in full overlay or inset door applications with tight tolerances, due to their construction.
- **Style 1271** doors and drawer fronts finish at 1⁵/₁₆" thick.
- **Style 1271** doors and drawer fronts can *only* be ordered with the **318-25RP, 319-10RP, 320-32RP, 321-32RP, 328-32RP** or **329-19RP** raised panel profiles. Please also specify the desired outside edge profile (ie: **D7, D33**, etc.). There is no additional charge to add an outside edge.
- **Style 1272** doors and drawer fronts finish at 1 1/8" thick.
- **Style 1272** doors and drawer fronts can be ordered with any RP style edge, with the *exception* of those listed above. Please also specify the desired outside edge profile (ie: **D7, D33**, etc.). There is no additional charge to add an outside edge.
- Minimum for pricing is **1 square foot** for doors and a **1/2 square foot** for drawer fronts, per item.
- Arrows shown throughout (↔) indicate standard grain direction.
- Grain direction may be specified at **NO** additional cost.
- Dashed lines on drawings indicate the battens that are attached to the back side of the door.
- Battens are not glued to the doors, they are attached with screws and if requested, these parts may be shipped loose.
- Holes in the battens are drilled oversized to allow for expansion and contraction.
- **Styles 1050, 1270, 1271 & 1272** can be ordered with or without battens attached. If ordering without battens, panels over 24" wide or 72" high will carry no warranty against warpage.



WalzCraft.com



(Phone) 1-800-237-1326 7:00AM - 4:30PM CST (24 Hour Fax) 1-608-781-3667

Contemporary Slab & Batten Doors

"WalzCraft is a Premier Leader in the Industry for Manufacturing Custom Products!"

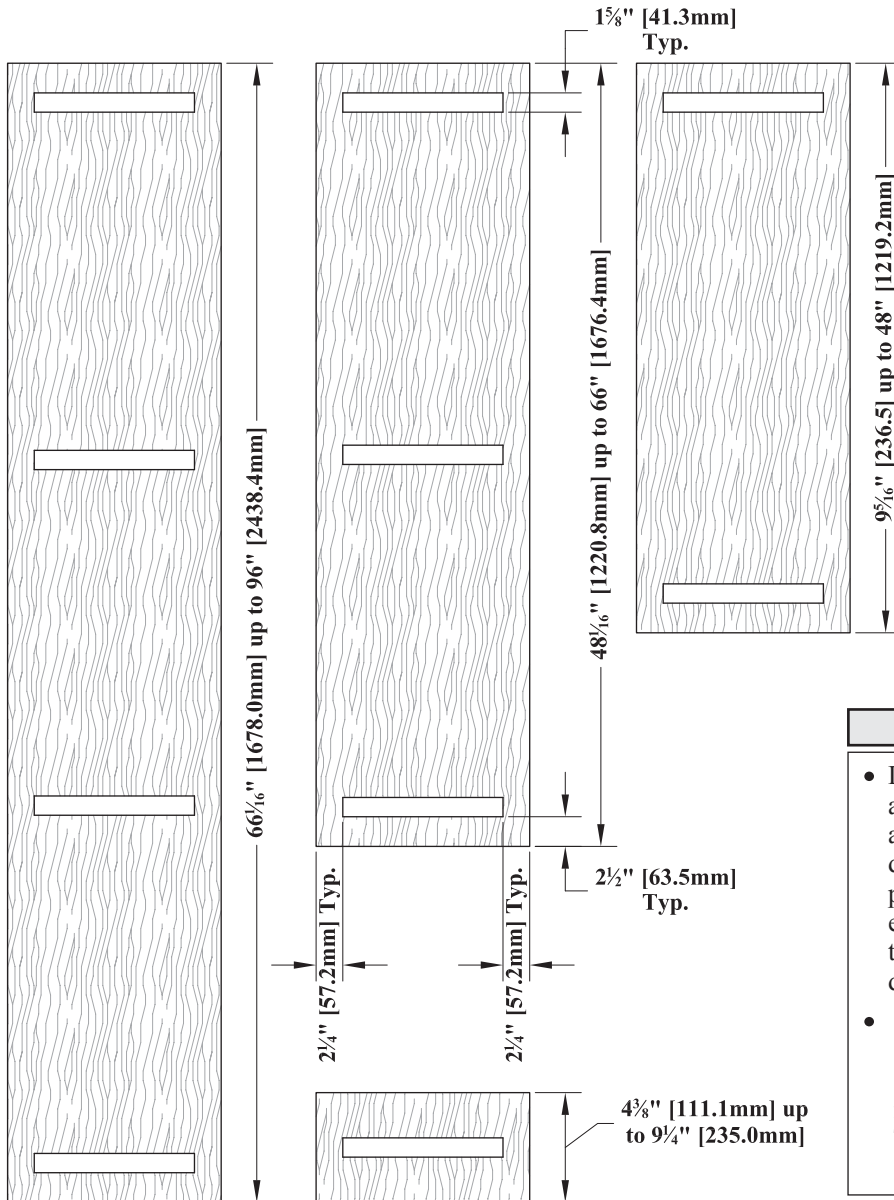

Batten Placement

- Door Styles 1050, 1270, 1271 and 1272 are shipped with matching wood battens attached by screws, to the back of the door. They are $\frac{11}{16}$ " thick x $\frac{15}{8}$ " wide; positioned $\frac{2}{4}$ " from the left & right edges of the door and $\frac{2}{2}$ " down from the top and up from the bottom of the door.
- Custom batten placement or sizing is available if our standard guidelines conflict with your hardware. Please refer these requests to our Non-Catalog Team. Additional design charges may apply.

Continuous Grain Pattern (Solid Wood or Veneer)

- WalzCraft **will** manufacture hardwood components using a Continuous Grain Pattern. To achieve this we build an oversized glued up panel and cut parts based on the dimensions needed for your configuration. *(The drawing to the right demonstrates how the grain flows continuously from one panel to the next. This option is ideal for a bank of drawer fronts or when the grain must be consistent between each center panel in a series of stacked doors.)*
- For more information please contact our Non-Catalog Team. Additional design charges may apply.

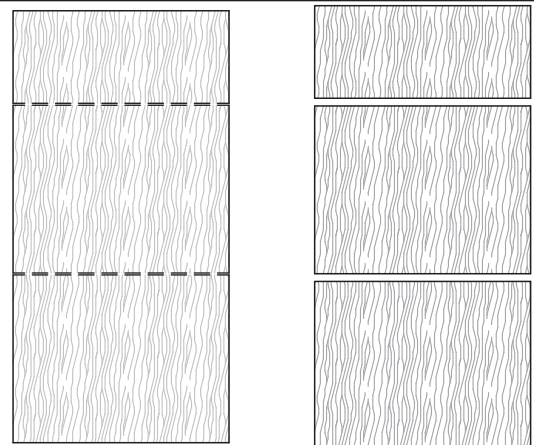

WalzCraft[®].com



(Phone) 1-800-237-1326 7:00AM - 4:30PM CST (24 Hour Fax) 1-608-781-3667

Contemporary Slab Doors

"Quality on time, every time!"

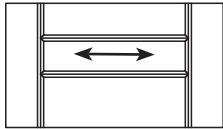

**Style 1025*
Drawer Front**

(Drawn at 8" high.)

Frame Group: A1
Price Class: 505
Min. Size: 6x3

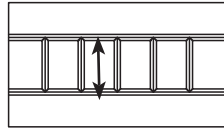

**Style 2510*
Drawer Front**

Frame Group: A1
Price Class: 504
Min. Size: 7x6
Max. Width: 30¹/₁₆

(If over the maximum width, order as a Style 2515.)

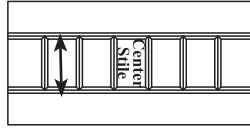

Style 2515*

Frame Group: A2
Price Class: 508
Min. Size: 30¹/₈x6

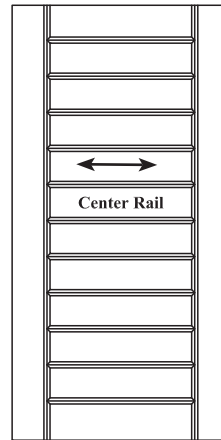

Style 1125

Frame Group: A2
Price Class: 507
Min. Size: 6x29³/₈

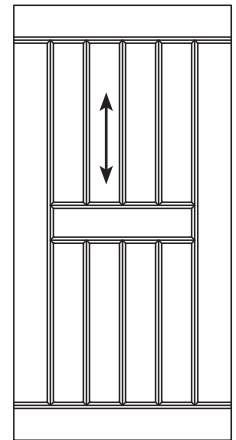

Style 2511

Frame Group: A2
Price Class: 506
Min. Size: 7x11¹/₄

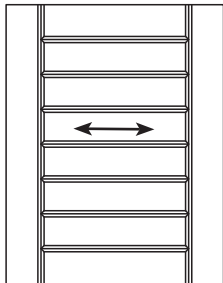

Style 1025

Frame Group: A1
Price Class: 505
Min. Size: 6x6
Max. Height: 29⁵/₁₆
(If over the maximum height, order as a Style 1125.)

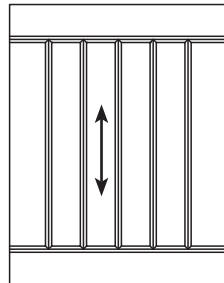

Style 2510

Frame Group: A1
Price Class: 504
Min. Size: 7x6
Max. Width: 30¹/₁₆
(If over the maximum width, order as a Style 2515.)

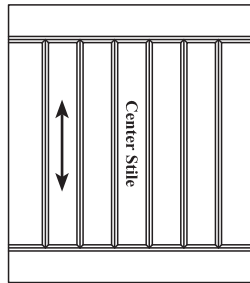

Style 2515

Frame Group: A2
Price Class: 508
Min. Size: 30¹/₈x6

Style 2510 Plank Sizes

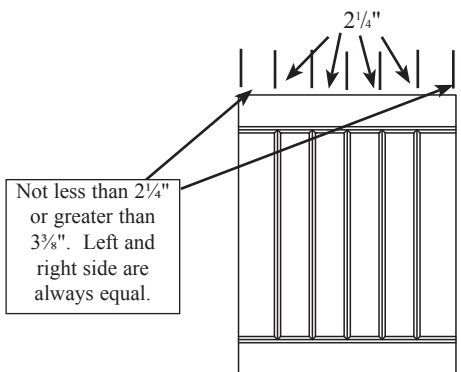

Style 1025 Plank Sizes

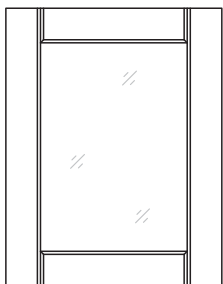
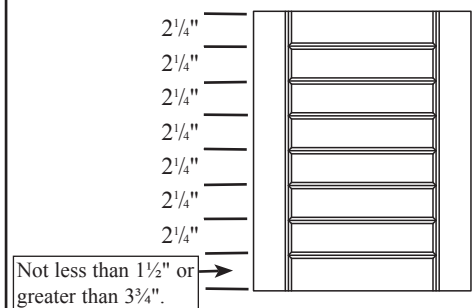

This is a view of our typical construction for a **Style #1025 Frame Door** with 2¹/₄" stiles & rails, using stile and rail profile **SR116GRF**.

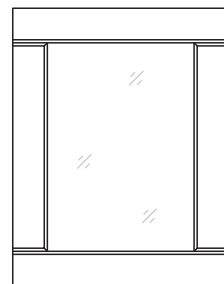

This is a view of our typical construction for a **Style #2510 Frame Door** with 2¹/₄" stiles & rails, using stile and rail profile **SR116GRF**.

Mortise & Tenon Slab Door Notes

- Arrows shown throughout (←→) indicate standard grain direction.
- Mortise and Tenon door design allows for center panel expansion and contraction.
- Minimum size for pricing door styles is **1 square foot** and a **1/2 square foot** for drawer front styles, per piece.
- The stile & rail and center panel profiles used when ordering these door styles are the **SR116** and **PR314-06**.
- Door **Styles 1025, 1025* and 1125** will have standard 2¹/₄" Top Rail, Left Stile & Right Stile dimensions, the Bottom Rail dimension will vary depending on the height.
- Door **Styles 2510, 2510* and 2511** will have standard 2¹/₄" Top Rail & Bottom Rail dimensions, the Left Stile & Right Stile dimension will vary depending on the width.



WalzCraft.com



(Phone) 1-800-237-1326 7:00AM - 4:30PM CST (24 Hour Fax) 1-608-781-3667